

IMPORTANT:
ASSEMBLY OF THIS
SHED REQUIRES TWO
PEOPLE

7x7 DOUBLE DOOR APEX SHED ASSEMBLY INSTRUCTIONS

FP10

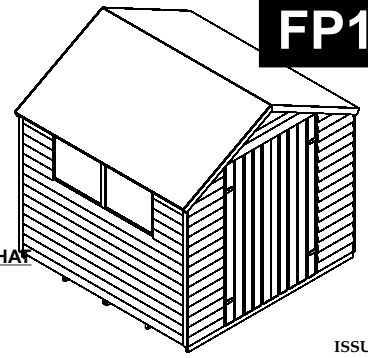

SHOULD YOU REQUIRE ANY ADDITIONAL GUIDANCE WITH THE ASSEMBLY OF YOUR SHED PLEASE CONTACT OUR TECHNICAL HELP LINE ON 0844 248 9853.

IMPORTANT NOTICE : THIS FIXING PACK IS UTILISED WITH SEVERAL DIFFERENT BUILDINGS. PLEASE ENSURE THAT WHEN ORDERING SPARE PARTS YOU QUOTE FROM THE RELEVANT COMPONENTS LIST.

IMPORTANT: RETAIN FOR FUTURE REFERENCE: READ CAREFULLY

ISSUE 0211

Thank you for choosing this garden building manufactured by the UK's largest manufacturer of timber garden products. In order to gain the most benefit from it, please note the following:

- Exercise particular care and follow instructions whilst cutting the roofing felt. If it is cut incorrectly, additional roofing felt can be inexpensively purchased from most good DIY retailers or garden centres.
- Most buildings are pre-treated with a factory base coat for protection during storage and transit. We recommend that you treat your new building as soon as possible after assembly, using a wood preservative treatment. Apply in accordance with the manufacturers instructions.
- If there are any technical queries with the product, please contact our customer help line on 0844 248 9853 between the hours of 8.30 am and 5.00 pm Monday to Friday.
- In line with your statutory rights, please check all parts prior to assembly, as assembly of damaged parts may be deemed to be acceptance and this may affect the remedies you are entitled to. If the product is not constructed in accordance with the instructions, or is altered in anyway (e.g. painted), the manufacturer cannot be held liable for any resulting damage.
- Timber is a natural material. It will shrink and swell as a result of varying moisture content.
- Please keep all plastic bags and small parts away from children in order to reduce the risk of suffocation.
- The roof of this product is not a load bearing structure.

REQUIRED TOOLS : (NOT SUPPLIED)

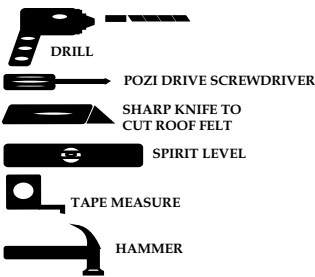

FP10 (FIXING PACK) CONTENTS :

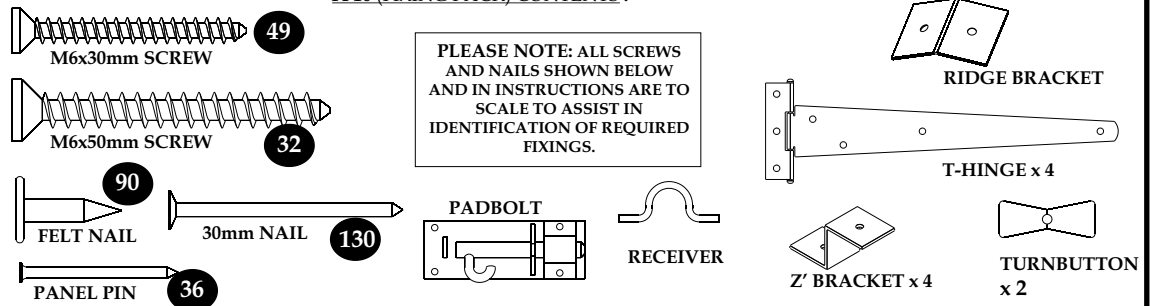

7x7 PRESSURE TREATED (ABQ77V2PTR) COMPONENTS INCLUDED

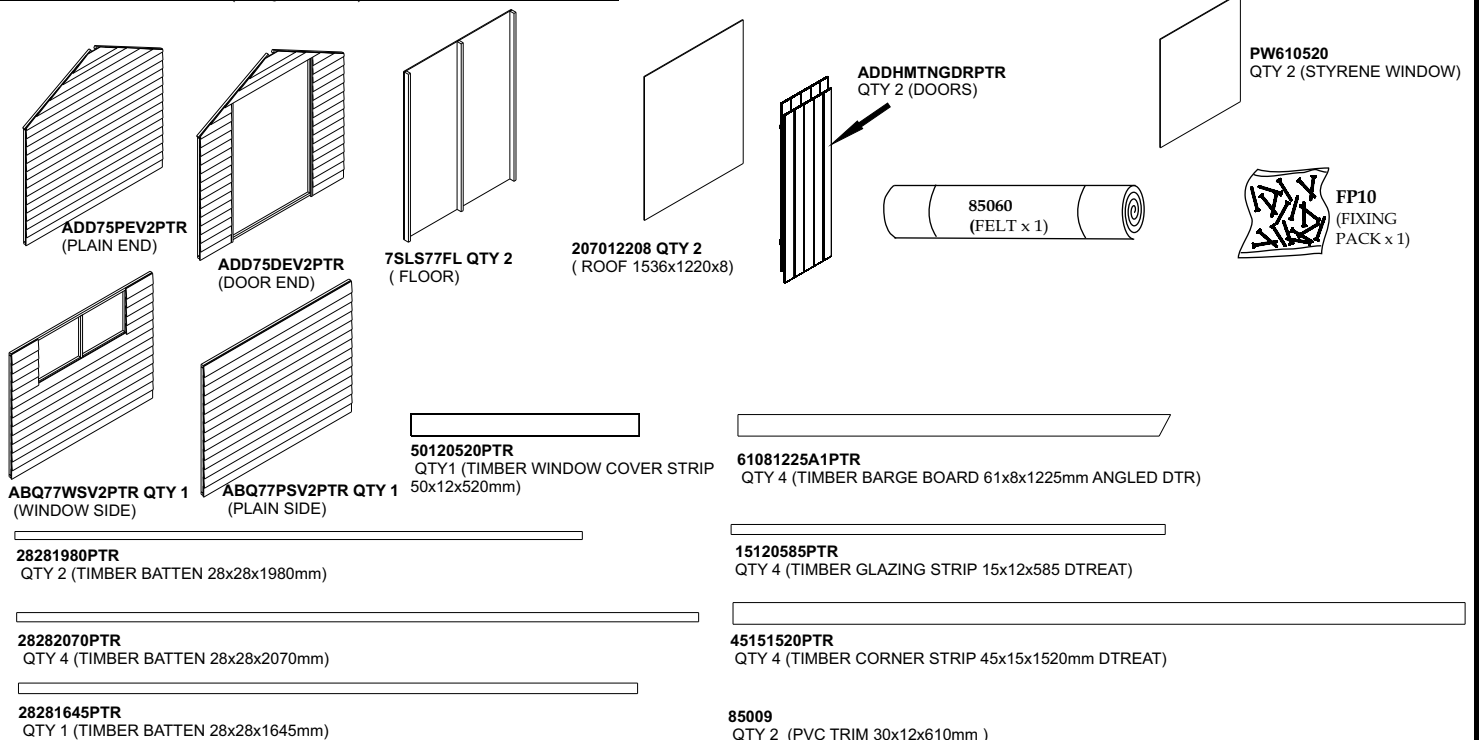

SHIPLAP 7x7 (SLS77) COMPONENTS INCLUDED

ISSUE 02111

SLS77PEV3
(PLAIN END)

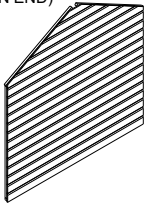

7SLS77FL QTY 2
(FLOOR)

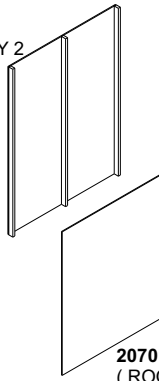

SLS77DEV3
(DOOR END)

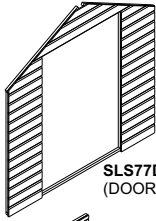

ADDHMTNGDR
QTY 2 (DOORS)

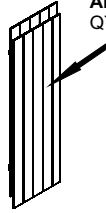

PW610610
QTY 2 (STYRENE WINDOW)

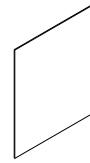

85060
FELT x 1

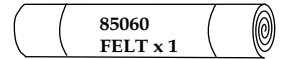

(FP 10)
FIXING
PACK x 1



SLS77PSV3
(PLAIN SIDE)

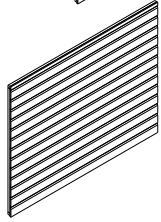

207012208 QTY 2
(ROOF 2070x1220x8)

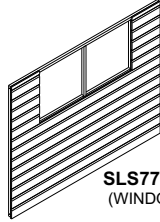

SLS77WSV4
(WINDOW SIDE))



52120600DTR
QTY 1 (TIMBER STRIP 52x12x600mm)

61081225A1DTR
QTY 4 (TIMBER BARGE BOARD 61x8x1225mm ANGLED)

15120585DTR
QTY 4 (TIMBER GLAZING STRIP 15x12x585 DTREAT)

28281980
QTY 2 (TIMBER BATTEN 28x28x1980mm)

28282070
QTY 4 (TIMBER BATTEN 28x28x2070mm)

28281645
QTY 1 (TIMBER BATTEN 28x28x1645mm)

85111
QTY 1 (PVC TRIM 30x12x1230mm)

7x7 OVERLAP SHED (HABQ77V2) COMPONENTS INCLUDED

207012208 QTY 2
(ROOF 1536x1220x8)

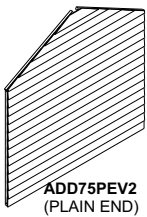

ADD75PEV2
(PLAIN END)

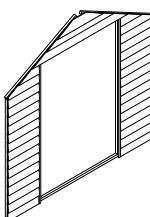

ADD75DEV2
(DOOR END)

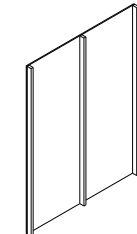

7SLS77FL QTY 2
(FLOOR)

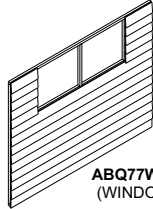

ABQ77WSV2 QTY2
(WINDOW SIDE))

50120520DTR
QTY2 (TIMBER WINDOW COVER STRIP 50x12x520mm)

28281980
QTY 2 (TIMBER BATTEN 28x28x1980mm)

28282070
QTY 4 (TIMBER BATTEN 28x28x2070mm)

ADDHMTNGDR
QTY 2 (DOORS)



PW610520
QTY 4 (STYRENE WINDOW)

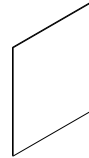

FELT69BL
(FELT x 1)



FP10
(FIXING
PACK x 1)



61081225A1DTR
QTY 4 (TIMBER BARGE BOARD 61x8x1225mm ANGLED DTR)

15120585DTR
QTY 8 (TIMBER GLAZING STRIP 15x12x585 DTREAT)

85009
QTY 4 (PVC TRIM 30x12x610mm)

45151520DTR
QTY 4 (TIMBER CORNER STRIP 45x15x1520mm DTREAT)

28281645
QTY 1 (TIMBER BATTEN 28x28x1645mm)

1

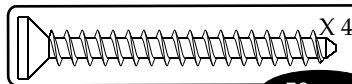

50mm

SECURE THE 2
7SLS77FL (FLOOR
SECTIONS)
TOGETHER USING
4x50mm SCREWS AS
SHOWN

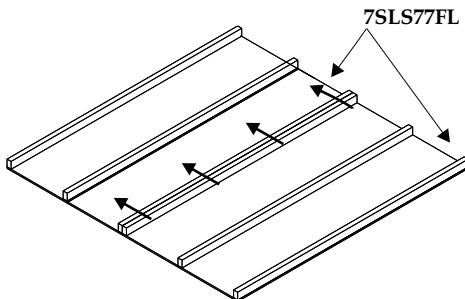

2



30mm

DOOR END

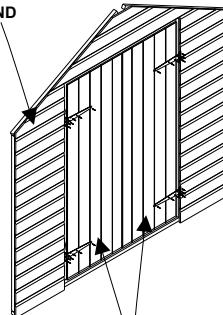

ADDHMTNGDR

A) FASTEN TWO HINGES TO EACH
ADDHMTNGDR (DOOR) AS SHOWN
USING 30mm SCREWS. SCREWS MUST
SECURE INTO THE TWO HORIZONTAL
BATTENS ON THE BACK OF THE
ADDHMTNGDR (DOOR).

B) PLACE **DOOR END** FACE UP ON
GROUND. LAY EACH **ADDHMTNGDR**
(DOOR) ON **ADD75DEV2** (DOOR END)
OF SHED ENSURING THAT THE DOORS
ARE SQUARE WITH EQUAL GAPS TO
LEFT AND RIGHT, AND SECURE
HINGES TO **DOOR END** WITH 30mm
SCREWS.

3

PLAIN END

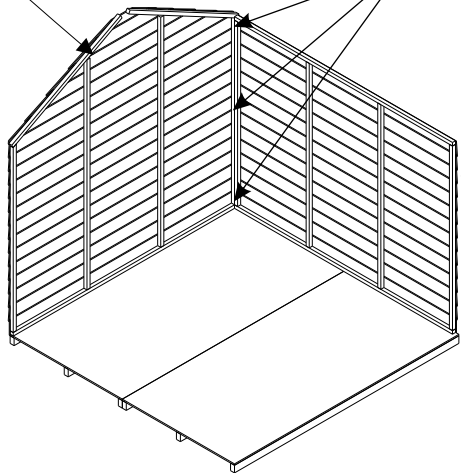
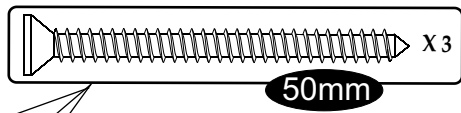

PLAIN SIDE

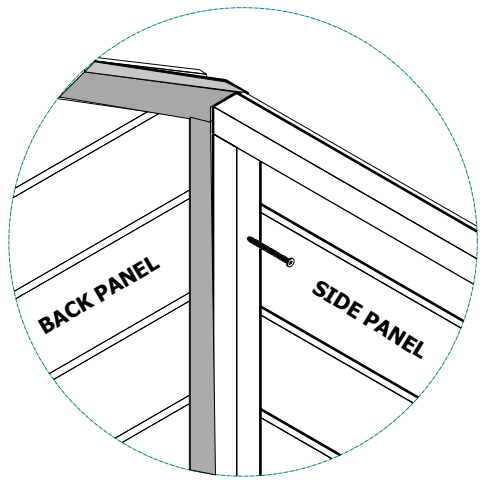

POSITION THE **PLAIN END** OF SHED ONTO FLOOR SO THAT THE LEFT AND RIGHT HAND EDGES OF THE PANEL ARE FLUSH WITH THE EDGES OF THE FLOOR. PLACE THE **PLAIN SIDE** PANEL ONTO THE FLOOR AND UP AGAINST THE **PLAIN END** PANEL. SECURE **SIDE** PANEL TO **PLAIN END** PANEL USING 3 x 50mm SCREWS PLACED AS SHOWN. **DO NOT SECURE THE PANELS TO THE FLOOR AT THIS POINT.**

HABQ77V2 (POSITION THE WINDOW SIDE)

4

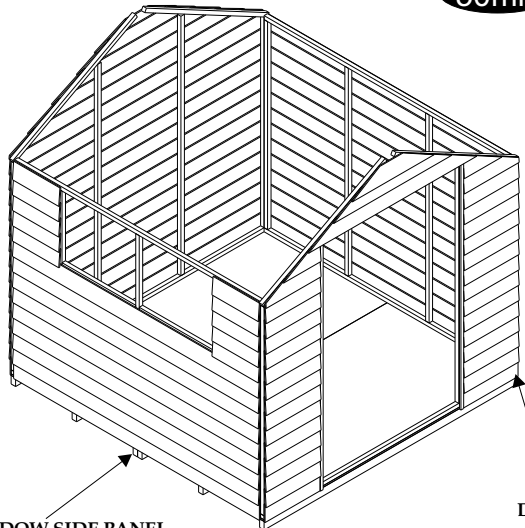
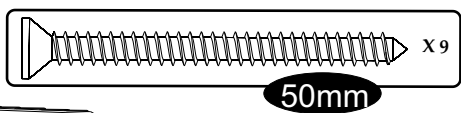

DOOR END

WINDOW SIDE PANEL

USING PROCEDURE OUTLINED IN STEP 3, POSITION AND SECURE THE REMAINING **WINDOW** PANEL AND **DOOR** END.

5

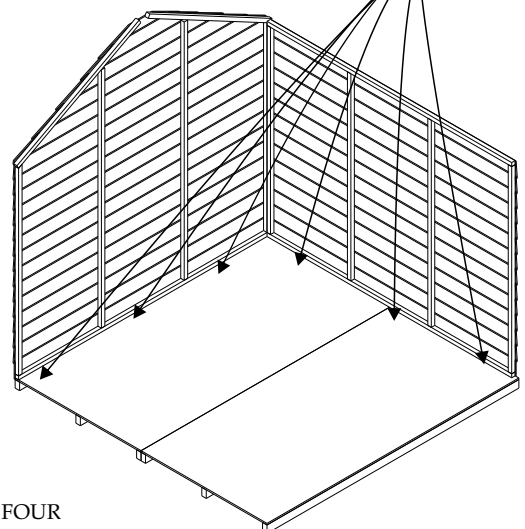
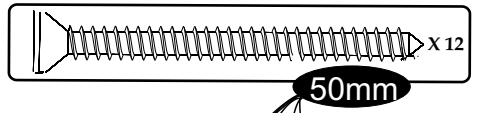

ONCE ALL FOUR OF THE PANELS ARE IN PLACE AND FASTENED TOGETHER, SECURE THEM TO THE FLOOR USING 50mm SCREWS. EACH PANELS REQUIRE 3 SCREWS. IT IS VITAL THAT ALL SCREWS ARE POSITIONED SO THAT THEY LOCATE INTO FLOOR BEARERS.

6

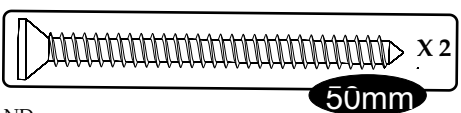

STAND INSIDE THE SHED AND WITH DOOR TO YOUR LEFT OPEN, ATTACH **28281645** (BATTEN) TO DOOR ON YOUR RIGHT WITH TWO 50mm SCREWS. IT IS VITAL THAT THERE IS AN EQUAL GAP BETWEEN THE **28281645** (BATTEN) AND THE DOOR OPENING AT THE TOP AND BOTTOM. THE SCREW MUST LOCATE THROUGH THE **28281645** (BATTEN) INTO EACH OF THE TWO HORIZONTAL BATTENS ON THE DOOR. ONCE THE **28281645** (BATTEN) IS IN PLACE FASTEN A **TURN BUTTON** TO THE TOP AND BOTTOM OF IT WITH A 50mm SCREW FOR EACH.

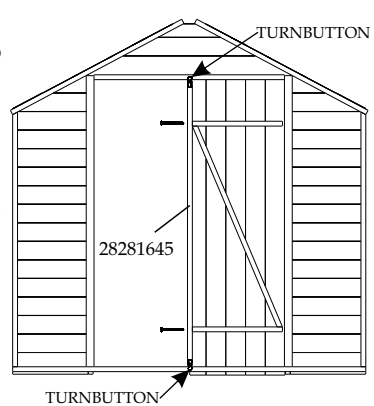

TURN BUTTON

28281645

TURN BUTTON

7

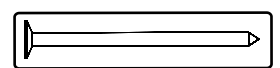

PLACE **207012208** (OSB ROOF) ON TOP OF **28282070** (BATTEN) MAKING SURE THAT IT IS FLUSH AGAINST THE EDGE AND CORNERS OF **207012208** (OSB ROOF). SECURE IN PLACE USING 30mm NAILS THROUGH THE (OSB ROOF) INTO THE **28282070** (BATTEN) AT 300mm INTERVALS. REPEAT THE PROCESS WITH ANOTHER **28282070** (BATTEN) BUT MAKING SURE IT IS OFFSET FROM THE EDGE BY 18mm.

DO THIS FOR BOTH ROOF SECTIONS

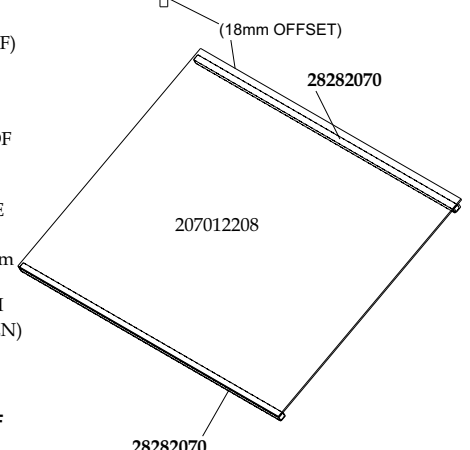

(18mm OFFSET)

28282070

207012208

28282070

8

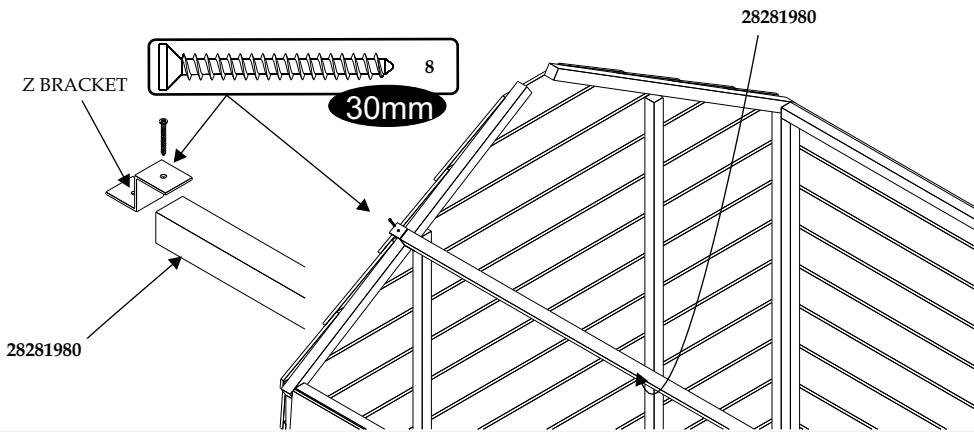

SECURE 1 "Z" BRACKET TO BOTH ENDS OF A **28281980** (BATTEN) WITH A 30mm SCREW. PLACE **28281980** (BATTEN) WITH "Z" BRACKETS BETWEEN ENDS OF SHED SO THAT THE "Z" BRACKET SITS ON TOP OF THE END SECTION FRAMEWORK AND UNDER THE ROOF BATTEN. THE **28281980** (BATTEN) WITH "Z" BRACKETS SHOULD BE PLACED APPROXIMATELY HALF WAY BETWEEN THE SIDE AND THE MIDDLE OF THE SHED AND THEN SECURED AT BOTH ENDS WITH A 30mm SCREW. REPEAT PROCEDURE WITH SECOND **28281980** (BATTEN) AND REMAINING 2 "Z" BRACKETS.

9

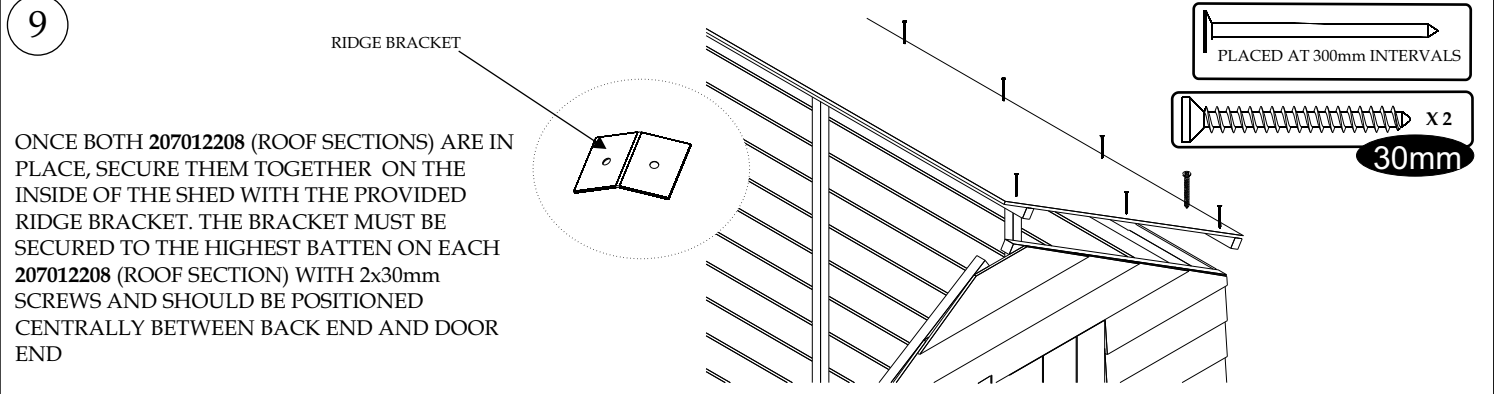

ONCE BOTH **207012208** (ROOF SECTIONS) ARE IN PLACE, SECURE THEM TOGETHER ON THE INSIDE OF THE SHED WITH THE PROVIDED RIDGE BRACKET. THE BRACKET MUST BE SECURED TO THE HIGHEST BATTEN ON EACH **207012208** (ROOF SECTION) WITH 2x30mm SCREWS AND SHOULD BE POSITIONED CENTRALLY BETWEEN BACK END AND DOOR END

PLACE ONE OF THE ASSEMBLED **207012208** (ROOF) SECTIONS ON TOP OF THE SHED. WHEN IN PLACE, THE **207012208** (ROOF) SECTION SHOULD OVERHANG BY EQUAL AMOUNTS AT EITHER END OF THE SHED AND SHOULD BE POSITIONED SO THAT WHEN BOTH **207012208** (ROOF) SECTIONS ARE IN PLACE THEY MEET AT A POINT. SECURE IN PLACE WITH 30mm NAILS PLACED AT 300mm INTERVALS INTO THE FRAMEWORK OF THE SIDES OF THE SHED.
REPEAT THIS PROCEDURE FOR THE REMAINING ROOF SECTION.

10

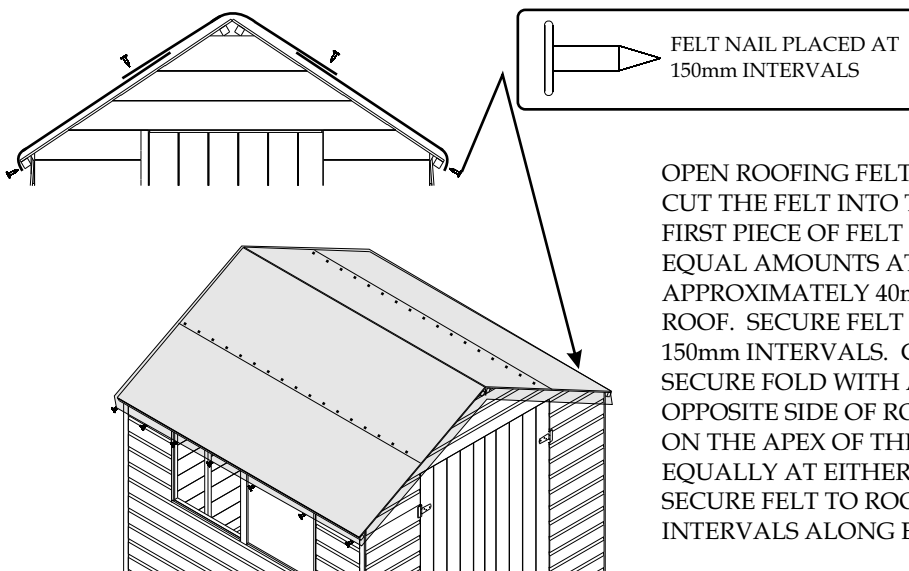

OPEN ROOFING FELT AND ROLL OUT FLAT ON GROUND. CUT THE FELT INTO THREE EQUAL LENGTHS. PLACE THE FIRST PIECE OF FELT ON THE ROOF SO THAT IT OVERLAPS EQUAL AMOUNTS AT EITHER END OF THE SHED, AND BY APPROXIMATELY 40mm AT THE EAVE (LOWER) SIDE OF THE ROOF. SECURE FELT TO ROOF WITH FELT NAILS PLACED AT 150mm INTERVALS. CUT AND FOLD FELT AT CORNERS AND SECURE FOLD WITH A FELT NAIL REPEAT PROCEDURE FOR OPPOSITE SIDE OF ROOF. PLACE THE THIRD PIECE OF FELT ON THE APEX OF THE ROOF SO THAT IT OVERLAPS EQUALLY AT EITHER END AND EITHER SIDE OF THE ROOF. SECURE FELT TO ROOF WITH FELT NAILS PLACED AT 150mm INTERVALS ALONG EITHER SIDE.

11

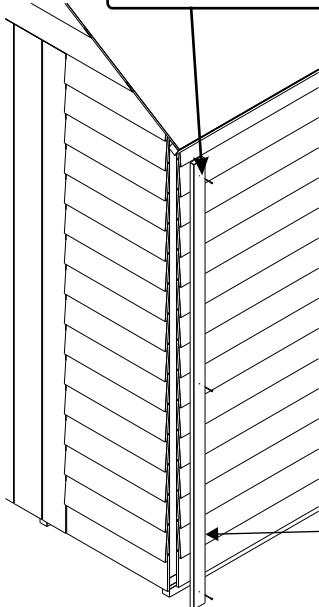
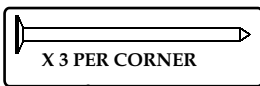

SECURE A **45151520** (CORNER STRIP) TO EACH OF THE FOUR CORNERS WITH 3 x 30mm NAILS PER STRIP. NAILS SHOULD BE PLACED APPROXIMATELY AS SHOWN. THE BOTTOM OF **45151520** (CORNER) STRIP SHOULD BE IN LINE WITH BOTTOM OF CLADDING ON SIDE PANELS.

45151520

12

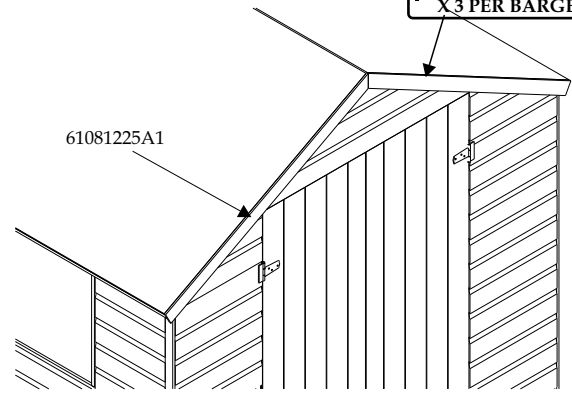
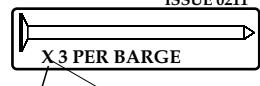

POSITION **61081225A1** (BARGE BOARDS) ON BOTH ENDS OF SHED SO THAT THE TOP EDGE IS IN LINE WITH THE TOP EDGE OF THE ROOF AND THE POINT OF THE **61081225A1** (BARGE BOARD) MEETS UP WITH THE HIGHEST POINT OF THE ROOF. SECURE EACH **61081225A1** (BARGE BOARD) IN PLACE WITH 3 x 30mm NAILS PLACED AS SHOWN ABOVE. TRIM OFF ANY EXCESS FELT THAT IS SHOWING BELOW THE **61081225A1** (BARGE BOARDS).

13

GLAZING STRIPS **15120585PTR** x 2 ON INTERIOR OF SHED

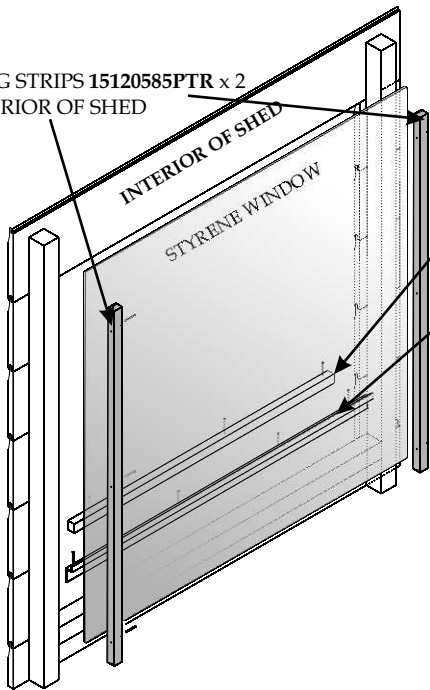

GLAZING STRIP **15120585PTR** x 1 ON EXTERIOR OF SHED

PLASTIC Z STRIP **85009** x 1 ON EXTERIOR OF SHED

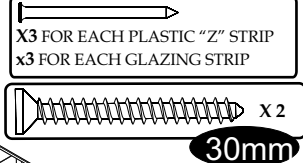
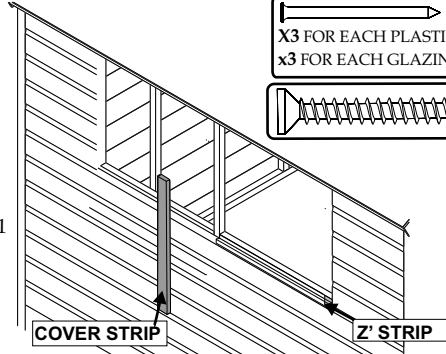

X 2
30mm

PLACE **85009** (PLASTIC "Z" STRIP) ACROSS BOTTOM OF THE WINDOW OPENING. THE LONG FACE OF THE Z SHOULD FACE DOWN ON THE OUTSIDE OF THE **ABQ86WSV2PTR** WINDOW SIDE. SECURE IN PLACE WITH 3 PANEL PINS. FIX THE **50120585PTR** (COVER STRIP) OVER THE CENTRAL BATTEN SO THAT IT IS EQUAL ON BOTH SIDES. SECURE USING 2 x 30mm SCREWS. PLACE **Pw610520** (WINDOW) INTO WINDOW OPENING FROM OUTSIDE OF SHED. THE BOTTOM OF THE **Pw610520** (WINDOW) SHOULD SIT ON TOP OF THE **85009** (PLASTIC "Z" STRIP). PLACE A **15120585PTR** (GLAZING STRIP) ALONG THE BOTTOM OF THE **Pw610520** (WINDOW) ON THE OUTSIDE OF THE SHED AND SECURE IN PLACE WITH 3 PANEL PINS. PLACE A **15120585PTR** (GLAZING STRIP) TO THE LEFT AND RIGHT OF THE **Pw610520** (WINDOW) FROM THE AND SECURE EACH IN PLACE WITH 3 PANEL PINS.

REPEAT THE GLAZING PROCEDURE

HABQV77V2 (REPEAT THIS STEP ON THE OTHER WINDOW PANEL)

14

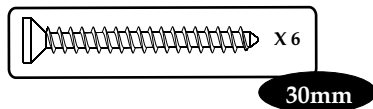

SECURE PAD BOLT TO OUTSIDE OF LH **ADDHMTNGDR** (DOOR) USING 3x30mm SCREWS. THE SCREWS MUST LOCATE INTO THE SHORT HORIZONTAL BATTEN ON THE INSIDE OF THE DOOR. SECURE RECEIVER TO RH **ADDHMTNGDR** DOOR USING 2 x30mm SCREWS.

