

SLOTTED COMPOSTER

- Most products are pre-treated with a factory base coat for protection during storage and transit. We recommend that you treat your new product as soon as possible after assembly, using a wood preservative treatment. Apply in accordance with the manufactures instructions. -Timber is a natural material. It will shrink and swell as a result of varying moisture content. -Please keep all plastic bags and small parts away from children in order to reduce the risk of suffocation.

0109

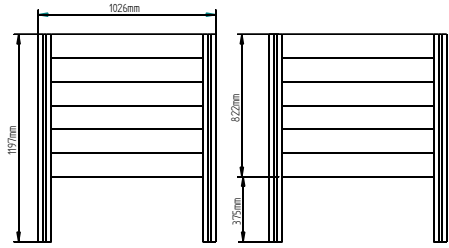

IMPORTANT :
ASSEMBLY OF THIS
PRODUCT REQUIRES TWO
PEOPLE

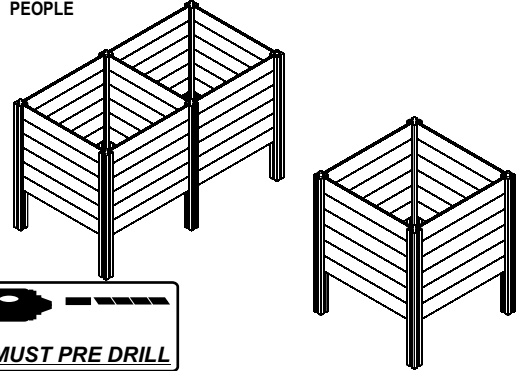

IMPORTANT. RETAIN FOR FUTURE REFERENCE: READ CAREFULLY

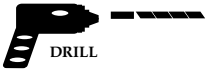

DRILL



TAPE MEASURE



WOOD SAW



SPIRIT LEVEL



POZI DRIVE SCREWDRIVER

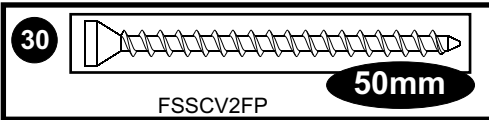

FSSCV2FP

50mm



SHOULD YOU REQUIRE ANY ADDITIONAL GUIDANCE WITH THE ASSEMBLY OF YOUR SHED PLEASE CONTACT OUR TECHNICAL HELP LINE ON 0844 248 9853.

FSSCV2

FSSCV2EXT

4



75751198SPTR

24

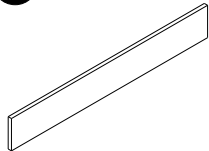

137160912PTR

2



75751198SPTR

18

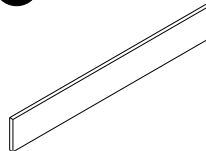

137160912PTR

Position the 4 **75751198SPTR** (posts) in a square formation as shown and sink 238mm into the ground.

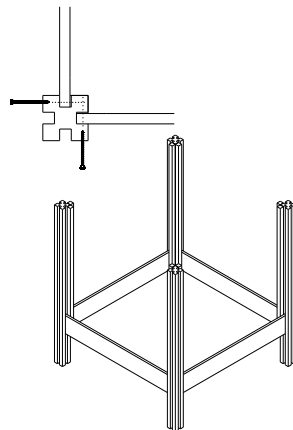
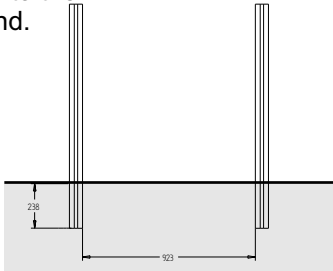

Slot the first row of **137160912PTR** (boards) into the framing secure 3 of the boards using the 50mm screws 2 per board. The one board you do not secure will be your access to the compost so position it in an accessible orientation.

Slot the remainder of the **137160912PTR** (boards) into position.

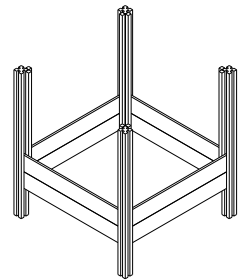

Secure all of the top **137160912PTR** (boards) using 2x50mm screws per board.

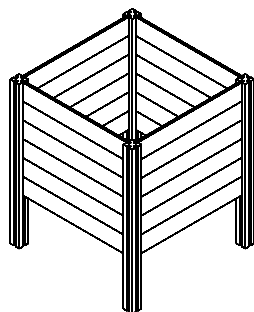

To retrieve the compost loosen the top screws and slide the boards up.

EXTENSION ONLY

